

L2032

■ Features of L2032 Series

- 20 characters × 2 lines
- 5 × 7 dot matrix + cursor
- 1/16 duty
- 5V single power supply

■ Specification

A. Mechanical Characteristics

Item	Specifications	Unit
Module size (H × V × T) (Reflective/built-in EL backlight type)	116.0 × 37.0 × 11.3	mm
Module size (H × V × T) (Built-in LED backlight type)	116.0 × 37.0 × 15.8	mm
Viewing area (H × V)	83.0 × 18.6	mm
Character size (5 × 7 dot, H × V)	3.20 × 4.85	mm
Dot size (H × V)	0.60 × 0.65	mm
Dot space	0.05	mm
Center to center dimension of mounting holes (H × V)	108.0 × 29.0	mm
Weight (Reflective type)	40	g
Weight (Built-in LED backlight type)	60	g
Weight (Built-in EL backlight type)	45	g

H : Horizontal, V : Vertical, T : Thickness (max.)

B. Absolute Maximum Ratings

V_{SS} = 0V

Item	Symbol	Conditions	Min.	Max.	Unit
Power supply voltage	V _{DD}		-0.3	7.0	V
	V _{LC}		V _{DD} -7.0	V _{DD} +0.3	V
Input voltage	V _{IN}		-0.3	V _{DD} +0.3	V
Operating temp.	T _{opr}		0	+50	°C
Storage temp.	T _{stg}		-20	+60	°C
Storage humidity		≤48hrs	+20	+85	%RH
		≤1000hrs	+20	+65	%RH

C. Electrical Characteristics

V_{DD} = 5V ± 5%, V_{SS} = 0V, Ta = 0°C to 50°C

Item	Symbol	Conditions	Min.	Typ.	Max.	Unit
Power supply voltage	V _{DD}		4.75	5.00	5.25	V
	V _{DD} -V _{LC}		3.0	—	6.0	V
Input voltage	High	V _{IH1}	2.2	—	V _{DD}	V
	Low	V _{IL1}	0	—	0.6	V
Output voltage	High	V _{OH1}	-I _{OH} = 0.205mA	2.4	—	V
	Low	V _{OL1}	I _{OL} = 1.2mA	—	—	0.4
Current consumption	I _{DD}	Ta = 25°C V _{DD} = 5V V _{LC} ***	—	2.0	3.0	mA
	I _{LC}		—	0.4	1.0	mA
Clock oscillation frequency	f _{osc}	Resistance oscillation	190	270	350	kHz

* Applied to DB₀ ~ DB₇, E, R/W, RS

** Applied to DB₀ ~ DB₇

*** TN LCD module : V_{LC} = 0.4V, STN LCD module : V_{LC} = 0.25V

D. Optical Characteristics

D-1 TN LCD module (reflective type)

Viewing angle : 6 o'clock (∅ = 0°), Ta = 25°C, V_{opr} = 4.6V

Item	Symbol	Conditions	Min.	Typ.	Max.	Unit
Viewing angle	θ ₁	C ≥ 2.0 ∅ = 0°	—	—	10	deg.
	θ ₂		45	—	—	
	θ ₂ - θ ₁		35	—	—	
Contrast	C	θ = 30°, ∅ = 0°	5	8	—	—
Response time (rise)	t _{on}	θ = 0° ∅ = 0°	—	40	80	ms
Response time (fall)	t _{off}		—	120	160	
Response time (rise)	t _{on}	θ = 0°, ∅ = 0° Ta = 0°C V _{opr} = 4.8V	—	240	330	ms
Response time (fall)	t _{off}		—	425	650	

D-2 STN LCD module (gray)

D-2-1 Reflective type

Viewing angle : 6 o'clock (∅ = 0°), Ta = 25°C, V_{opr} = 4.75V

Item	Symbol	Conditions	Min.	Typ.	Max.	Unit
Viewing angle	θ ₁	C ≥ 2.0 ∅ = 0°	—	—	-15	deg.
	θ ₂		55	—	—	
	θ ₂ - θ ₁		70	—	—	
Contrast	C	θ = 25°, ∅ = 0°	2	4	—	—
Response time (rise)	t _{on}	θ = 0° ∅ = 0°	—	270	400	ms
Response time (fall)	t _{off}		—	60	100	
Response time (rise)	t _{on}	θ = 0°, ∅ = 0° Ta = 0°C V _{opr} = 5.0V	—	720	1100	ms
Response time (fall)	t _{off}		—	170	350	

D-2-2 Transflective type

Viewing angle : 6 o'clock (∅ = 0°), Ta = 25°C, V_{opr} = 4.75V, Backlight OFF

Item	Symbol	Conditions	Min.	Typ.	Max.	Unit
Viewing angle	θ ₁	C ≥ 2.0 ∅ = 0°	—	—	-10	deg.
	θ ₂		50	—	—	
	θ ₂ - θ ₁		60	—	—	
Contrast	C	θ = 25°, ∅ = 0°	2	4	—	—
Response time (rise)	t _{on}	θ = 0° ∅ = 0°	—	270	400	ms
Response time (fall)	t _{off}		—	60	100	
Response time (rise)	t _{on}	θ = 0°, ∅ = 0° Ta = 0°C V _{opr} = 5.0V	—	720	1100	ms
Response time (fall)	t _{off}		—	170	350	

E. Recommended Operating Voltage

The recommended value of (V_{opr}) for an ambient temperature is as follows.

E-1 TN LCD module

V_{opr} = V_{DD}-V_{LC}

Temperature (°C)	0	25	50
V _{opr} (V)	4.8	4.6	4.1

E-2 STN LCD module (gray)

V_{opr} = V_{DD}-V_{LC}

Temperature (°C)	0	25	50
V _{opr} (V)	5.00	4.75	4.50

■ TN/STN Reflective type

Item	L2032000000	L203200J000
Mechanical Characteristics	A	A
Absolute Maximum Ratings	B	B
Electrical Characteristics	C	C
Optical Characteristics	D-1	D-2-1
Recommended Operating Voltage	E-1	E-2

F-1 Power Supply

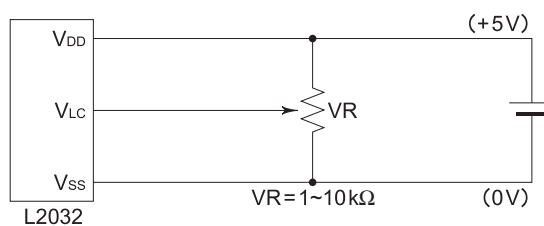

F-2 Dimensions

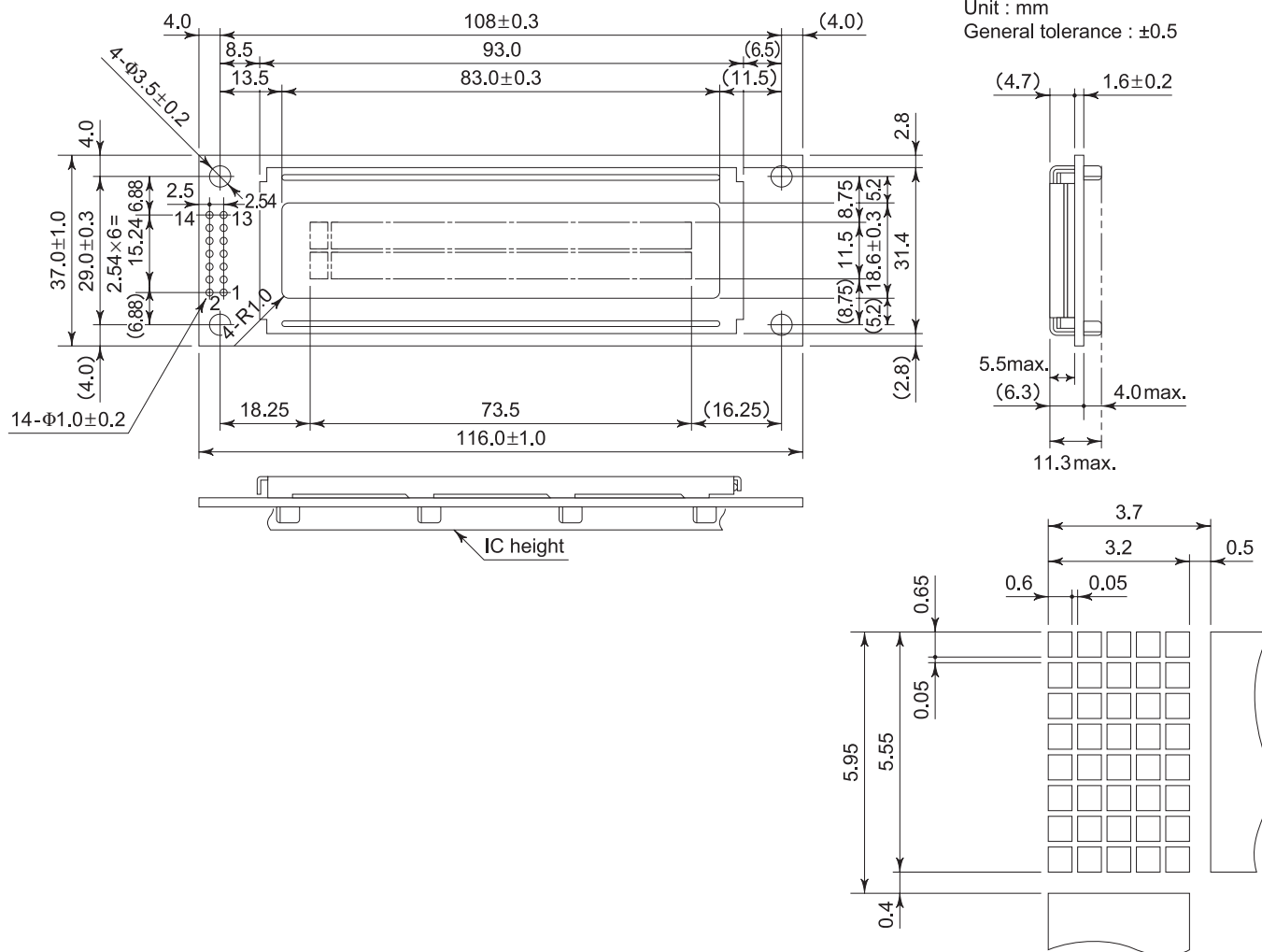

F-3 Pin Functions

No.	Name	Function
1	VSS	GND
2	VDD	Power supply voltage +5V
3	VLC	Liquid crystal driving voltage
4	RS	L : Instruction code input, H : Data input
5	R/W	L : Data write (LCM←MPU), H : Data read (LCM→MPU)
6	E	Enable
7	DB ₀	Data bus line
8	DB ₁	Data bus line
9	DB ₂	Data bus line
10	DB ₃	Data bus line
11	DB ₄	Data bus line
12	DB ₅	Data bus line
13	DB ₆	Data bus line
14	DB ₇	Data bus line

F-4 Block Diagram

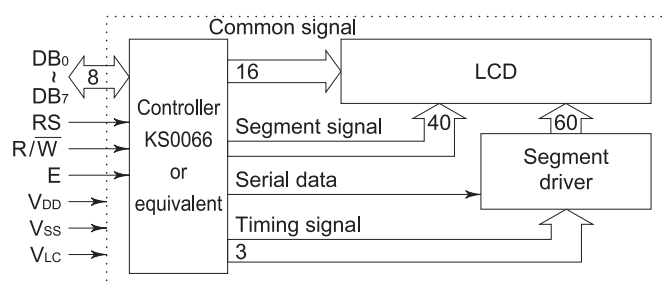

L2032

■ STN Transflective, Built-in LED Backlight type

Item	L2032B1J000
Mechanical Characteristics	A
Absolute Maximum Ratings	B
Electrical Characteristics	C
Optical Characteristics	D-2-2
Recommended Operating Voltage	E-2

G-1 Power Supply

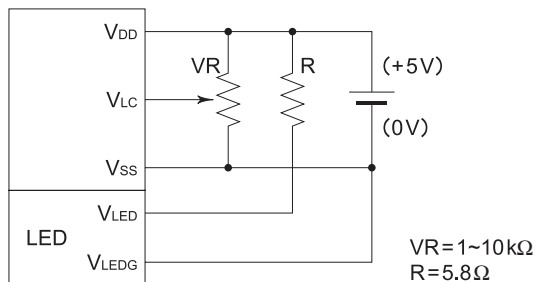

G-2 Dimensions

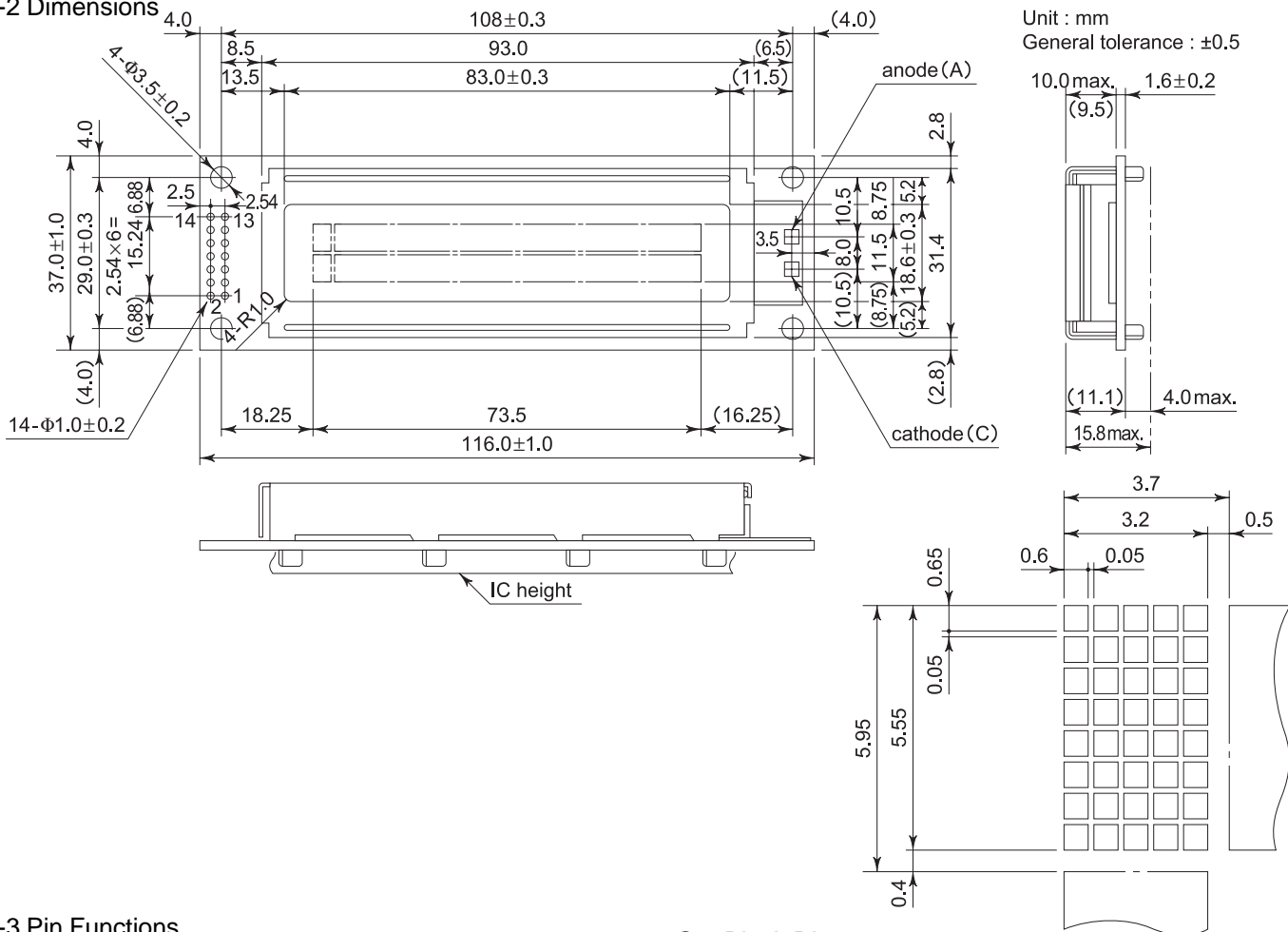

G-3 Pin Functions

No.	Name	Function
1	VSS	GND
2	VDD	Power supply voltage +5V
3	VLC	Liquid crystal driving voltage
4	RS	L : Instruction code input, H : Data input
5	R/W	L : Data write (LCM←MPU), H : Data read (LCM→MPU)
6	E	Enable
7	DB ₀	Data bus line
8	DB ₁	Data bus line
9	DB ₂	Data bus line
10	DB ₃	Data bus line
11	DB ₄	Data bus line
12	DB ₅	Data bus line
13	DB ₆	Data bus line
14	DB ₇	Data bus line

G-4 Block Diagram

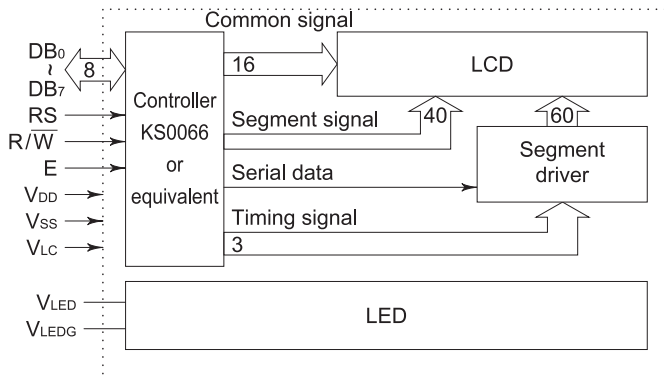

G-5 LED Backlight

G-5-1 LED Circuit Diagram

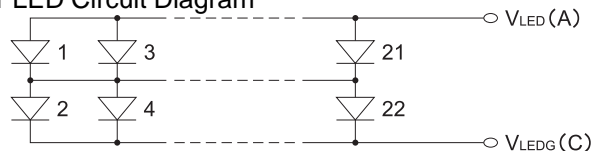

G-5-2 Absolute Maximum Ratings

Ta = 25°C

Item	Symbol	Specifications	Unit
LED forward current consumption*	IF	275	mA
LED reverse voltage	VR	8	V
LED allowable dissipation	PD	1.27	W

* LED forward current consumption and operating temperature characteristics are as follows.

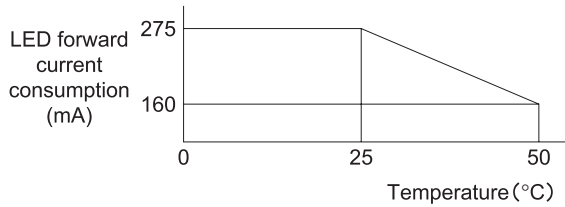

G-5-3 Electrical Characteristics

Ta = 25°C

Item	Symbol	Conditions	Min.	Typ.	Max.	Unit
LED forward input voltage	VF	IF = 154mA	3.8	4.1	4.4	V
LED reverse current	IR	VR = 8V	—	—	0.22	mA

G-5-4 Optical Characteristics

Ta = 25°C

Item	Symbol	Conditions	Specifications	Unit
Surface brightness (panel upper side)	Bp	IF = 154mA Vopr = 0V	8 min. 10 typ.	cd/m ²
LED brightness	L	IF = 154mA	40 min. 50 typ.	cd/m ²
LED service life			50,000 typ.	h
LED color			Yellowgreen	

■ STN Transflective, Built-in EL Backlight type

Item	L203221J000
Mechanical Characteristics	A
Absolute Maximum Ratings	B
Electrical Characteristics	C
Optical Characteristics	D-2-2
Recommended Operating Voltage	E-2

H-1 Power Supply

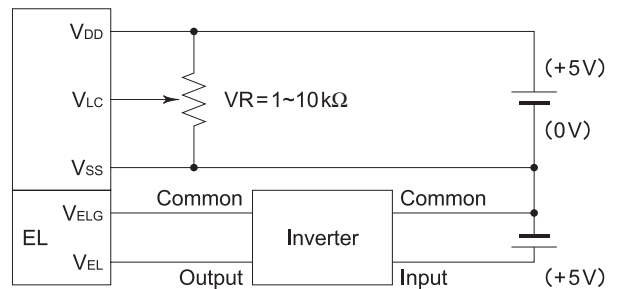

H-2 Dimensions

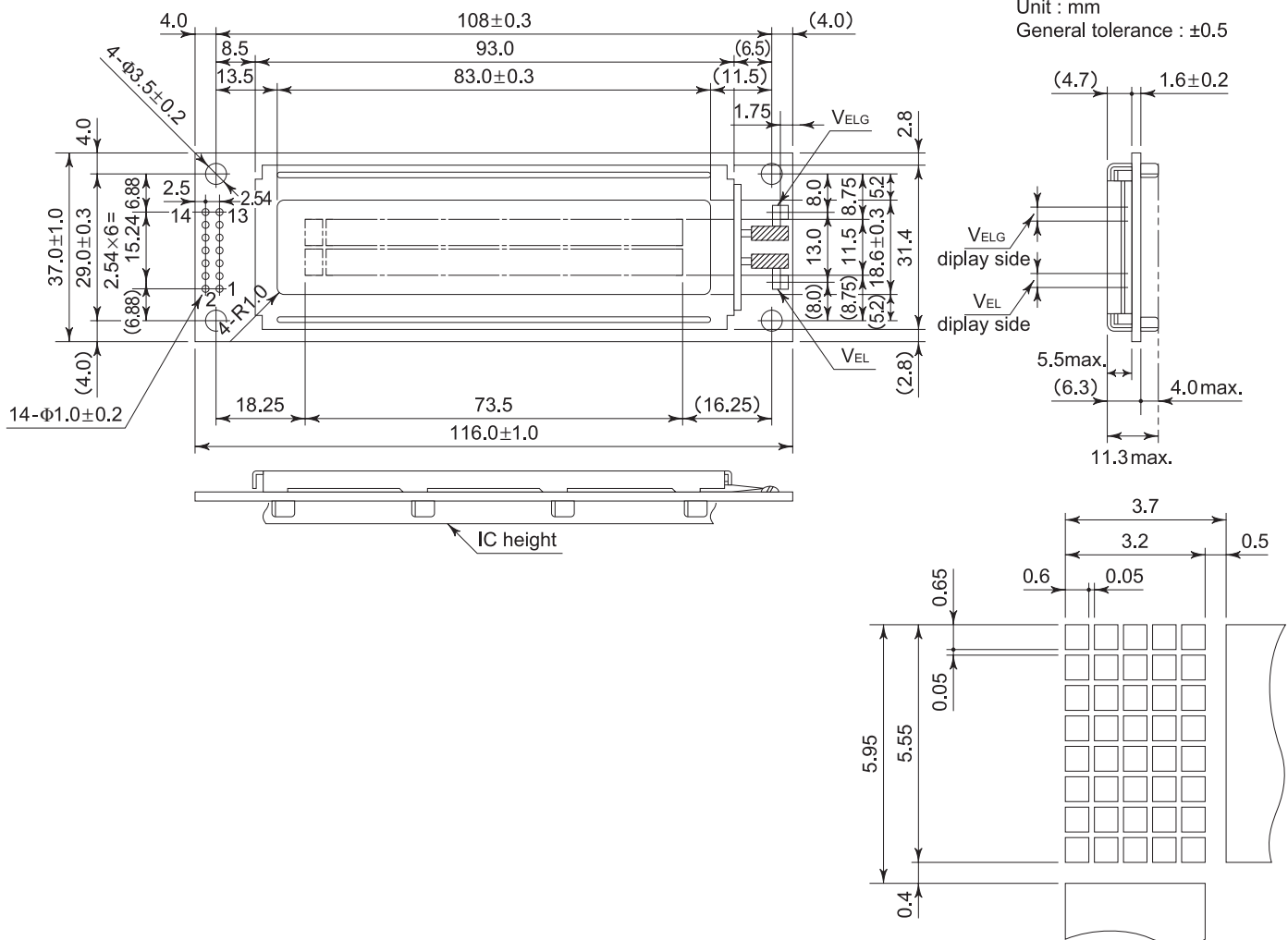

L2032

H-3 Pin Functions

No.	Name	Function
1	V _{SS}	GND
2	V _{DD}	Power supply voltage +5V
3	V _{LC}	Liquid crystal driving voltage
4	RS	L : Instruction code input H : Data input
5	R/W	L : Data write (LCM←MPU) H : Data read (LCM→MPU)
6	E	Enable
7	DB ₀	Data bus line
8	DB ₁	Data bus line
9	DB ₂	Data bus line
10	DB ₃	Data bus line
11	DB ₄	Data bus line
12	DB ₅	Data bus line
13	DB ₆	Data bus line
14	DB ₇	Data bus line

H-4 Block Diagram

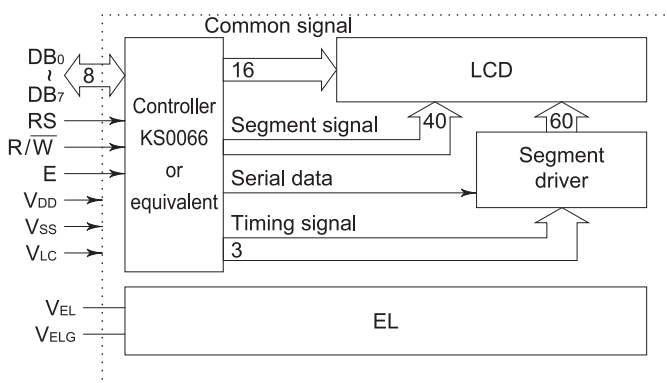

H-5 EL Lamp (white)

H-5-1 Environmental Characteristics

Item	Symbol	Conditions	Specifications
Operating temperature range	T _{opr}		-20°C to +50°C
Storage temperature range	T _{stg}		-20°C to +60°C
Soldering heat-resistance		270°C ± 5°C, 3 s max.	No terminal abnormality
Thermal shock		-20°C 30 min. ↔ +60°C 30 min. 5 cycles	No defect on appearance

H-5-2 Electrical Characteristics

Item	Symbol	Conditions	Spec.	Unit
Electrostatic capacity	C _{EL}	f = 1 kHz (in darkroom) 2 VAC	5.5 typ.	nF
Current	I _{EL}	When applying rated voltage, 20°C, 70%RH	3.0 max. 2.2 typ.	mA
Maximum rated voltage	VEL1	Sine wave, 1 kHz	150	Vrms
Rated voltage	VEL2	Sine wave, 400 Hz	100	Vrms
Isolation voltage		Between lead and film Sine wave, 50 Hz, 1 min.	1500	Vrms

H-5-3 Emission Characteristics

Item	Conditions	Specifications	Unit
Initial brightness (B)	When applying rated voltage 20°C, 70%RH (in darkroom)	30 min. 35 typ.	cd/m ²
Service life when applying rated voltage	Used continuously down to half of initial brightness 20°C, 70%RH	1500	h
Service life when used with an inverter	Used continuously down to half of initial brightness 20°C, 70%RH	4000	h
Color of light		White	—
Chromaticity coordinates	When applying rated voltage 20°C, 70%RH (in darkroom)	x = 0.315 typ. y = 0.375 typ. x = 0.285 min. y = 0.345 min. x = 0.355 max. y = 0.415 max.	—

H-6 Suitable Inverter 5A

H-6-1 Electrical Characteristics (when combined with EL lamp)

Item	Symbol	Conditions	Specifications	Unit
Oscillating frequency	f _{INV}	T _a = 25°C, V _{IN} = 5 VDC	350 typ.	Hz
Output voltage	V _{OUT}	T _a = 25°C, V _{IN} = 5 VDC	95 typ.	V
Output current	I _{OUT}	T _a = 25°C, V _{IN} = 5 VDC	1.5 typ.	mA
Input current	I _{IN}	T _a = 25°C, V _{IN} = 5 VDC	45 typ.	mA
Input voltage	V _{IN}		5 typ.	V DC
Initial brightness	B	T _a = 25°C, V _{IN} = 5 VDC	35 typ.	cd/m ²
Surface brightness (panel upper side)	B _p	T _a = 25°C, V _{IN} = 5 VDC V _{opr} = 0V	7 typ.	cd/m ²

H-6-2 Tolerance (inverter only)

Item	Specifications	Unit
Input voltage	3.0 to 6.0	V
Load range	5 to 20	cm ²

H-6-3 Maximum ratings (inverter only)

Item	Specifications	Unit
Input voltage	7.0	V
Load range	25	cm ²
Operating temperature range	-10 to +60	°C
Storage temperature range	-20 to +70	°C

H-6-4 Dimensions (Unit : mm)

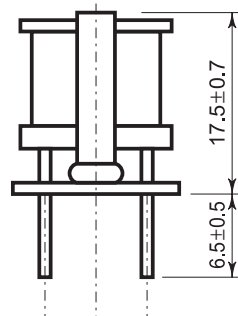

Pin No.	Functions
1	Input : 5V DC
2	Common : GND
3	Output

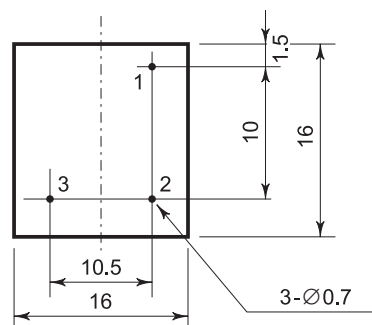

Wide Temperature Range STN LCD Module

■ Specification

J. Absolute Maximum Ratings

V_{SS} = 0V

Item	Symbol	Conditions	Min.	Max.	Unit
Power supply voltage	V _{DD}		-0.3	7.0	V
	V _{LC}		V _{DD} -7.0	V _{DD} +0.3	V
Input voltage	V _{IN}		-0.3	V _{DD} +0.3	V
Operating temp.	T _{opr}		-20	+70	°C
Storage temp.	T _{stg}		-30	+80	°C
Storage humidity		≤48hrs	+20	+85	%RH
		≤1000hrs	+20	+65	%RH

K. Electrical Characteristics

V_{DD} = 5V ± 5%, V_{SS} = 0V, T_a = -20°C to +70°C

Item	Symbol	Conditions	Min.	Typ.	Max.	Unit
Power supply voltage	V _{DD}		4.75	5.00	5.25	V
	V _{DD} -V _{LC}		3.0	—	6.0	V
Input voltage *	High	V _{IH1}	2.2	—	V _{DD}	V
	Low	V _{IL1}	0	—	0.6	V
Output voltage **	High	V _{OH1}	-I _{OH} = 0.205mA	2.4	—	V
	Low	V _{OL1}	I _{OL} = 1.2mA	—	—	0.4
Current consumption	I _{DD}	T _a = 25°C V _{DD} = 5V V _{LC} = 0.2V	—	2.0	3.0	mA
	I _{LC}		—	0.4	1.0	mA
Clock oscillation frequency	f _{osc}	Resistance oscillation	190	270	350	kHz

* Applied to DB₀ ~ DB₇, E, R/W, RS** Applied to DB₀ ~ DB₇

L. Optical Characteristics

The background color is affected by ambient temperature, and the response characteristics deteriorates at low temperature.

• Reflective/transflective type

Viewing angle : 6 o'clock (∅ = 0°), T_a = 25°C, V_{opr} = 4.8V, Backlight OFF

Item	Symbol	Conditions	Min.	Typ.	Max.	Unit
Viewing angle	∅ ₁	C ≥ 2.0 ∅ = 0°	—	—	0	deg.
	∅ ₂		50	—	—	
	∅ ₂ - ∅ ₁		50	—	—	
Contrast	C	∅ = 20°, ∅ = 0°	2	3	—	—
Response time (rise)	t _{on}	∅ = 0°	—	50	80	ms
Response time (fall)	t _{off}	∅ = 0°	—	100	160	
Response time (rise)	t _{on}	∅ = 0°, ∅ = 0° T _a = 0°C V _{opr} = 4.9V	—	200	320	ms
Response time (fall)	t _{off}		—	450	720	
Response time (rise)	t _{on}	∅ = 0°, ∅ = 0° T _a = -20°C V _{opr} = 5.0V	—	1500	2400	ms
Response time (fall)	t _{off}		—	1500	2400	

M. Recommended Operating Voltage

The recommended value of (V_{opr}) for an ambient temperature is as follows.

V_{opr} = V_{DD}-V_{LC}

Temperature (°C)	-20	0	25	70
V _{opr} (V)	5.0	4.9	4.8	4.2

■ Reflective type

Item	L203200P000
Mechanical Characteristics	A
Absolute Maximum Ratings	J
Electrical Characteristics	K
Optical Characteristics	L
Recommended Operating Voltage	M
Reflective type	
Power Supply	F-1
Dimensions	F-2
Pin Functions	F-3
Block Diagram	F-4

■ Built-in LED Backlight type

Item	L2032B1P000
Mechanical Characteristics	A
Absolute Maximum Ratings	J
Electrical Characteristics	K
Optical Characteristics	L
Recommended Operating Voltage	M
Transflective Built-in LED Backlight type	
Dimensions	G-2
Pin Functions	G-3
Block Diagram	G-4
LED Circuit Diagram	G-5-1
Electrical Characteristics (LED)	G-5-3

P. LED Backlight

P-1 Absolute Maximum Ratings

T_a = 25°C

Item	Symbol	Specifications	Unit
LED forward current consumption *	I _F	275	mA
LED reverse voltage	V _R	8	V
LED allowable dissipation	P _D	1.27	W

* LED forward current consumption and operating temperature characteristics are as follows.

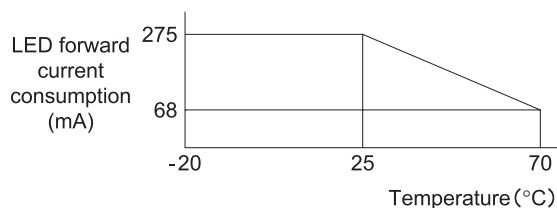

P-2 Optical Characteristics

T_a = 25°C

Item	Symbol	Conditions	Specifications	Unit
Surface brightness (panel upper side)	B _p	I _F = 154mA* V _{opr} = 0V	4 min. 5 typ.	cd/m ²
LED brightness	L	I _F = 154mA*	40 min. 50 typ.	cd/m ²
LED service life			50,000 typ.	h
LED color			Yellowgreen	

* The forward current depends upon the temperature. Especially, it must be decreased at high temperature. For temperature dependence, refer to forward current reduction characteristics.